

QUIZSWITHLAMP

THREE PLAYER  
'HIGH' EXAMPLE  
(FOR STANDING  
CONTESTANTS)

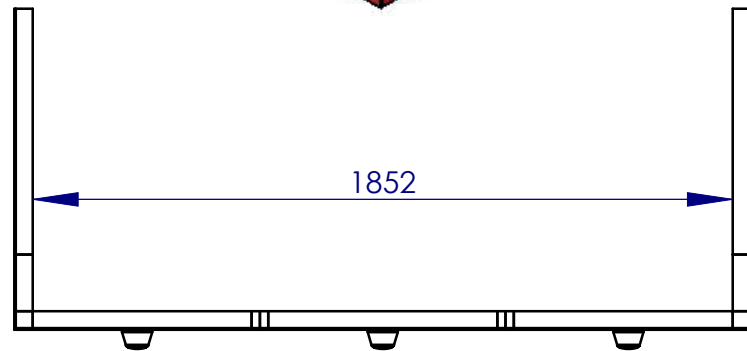

1852

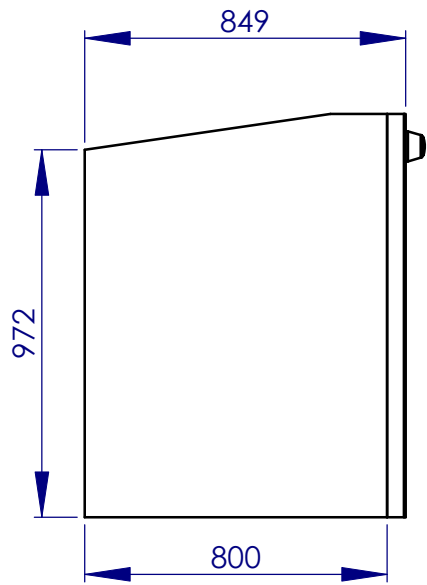

849

972

800

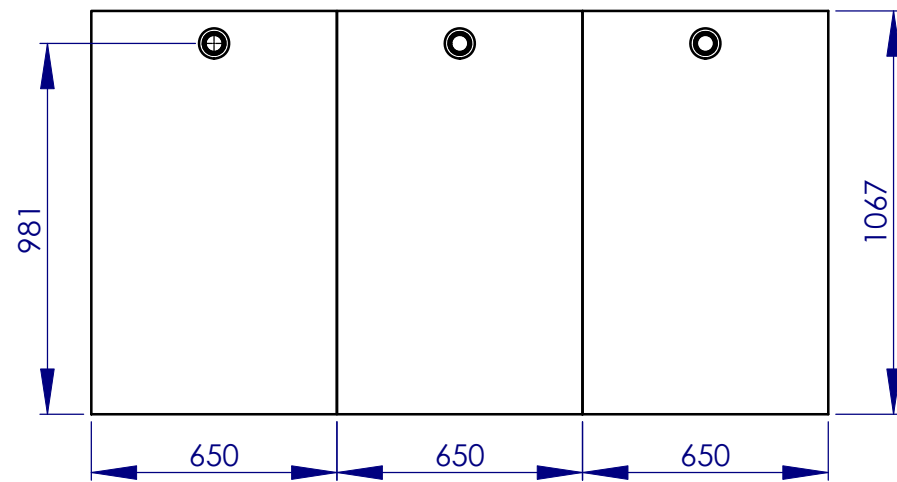

981

1067

650

650

650

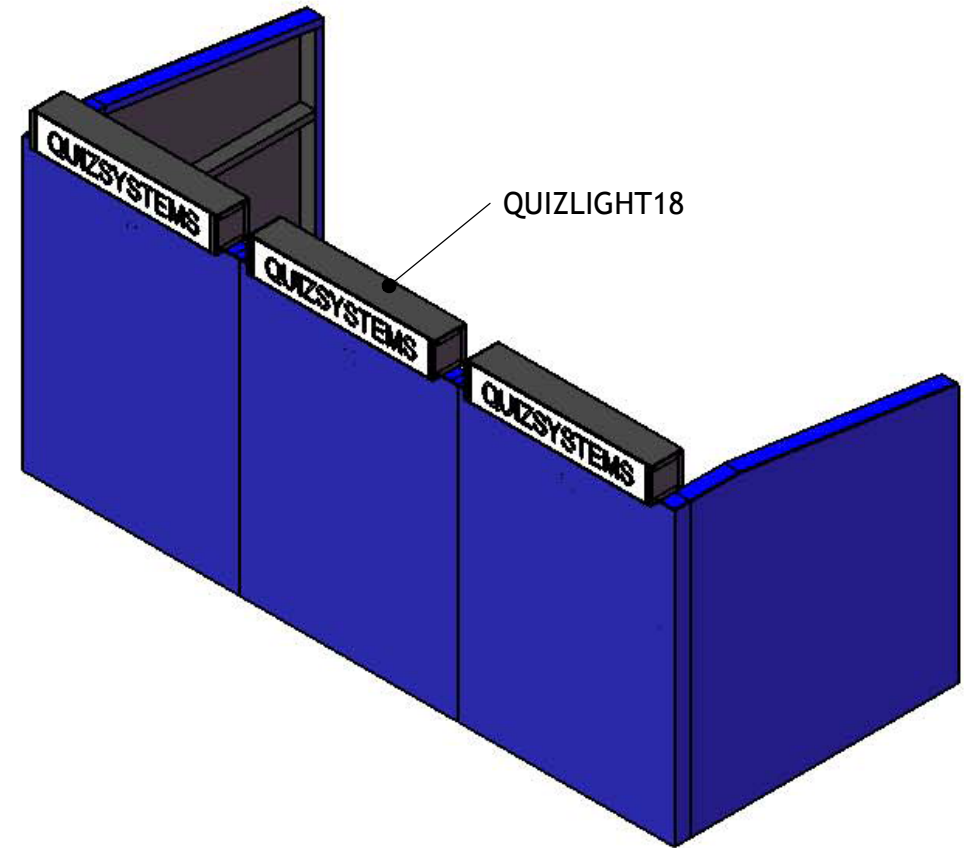

QUIZLIGHT18

THREE PLAYER  
'LOW' EXAMPLE  
(FOR SEATED  
CONTESTANTS)

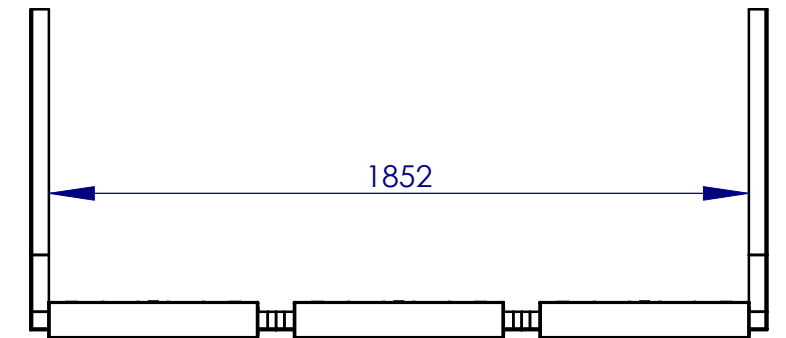

1852

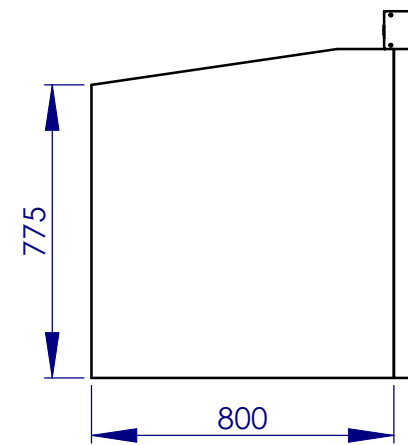

775

800

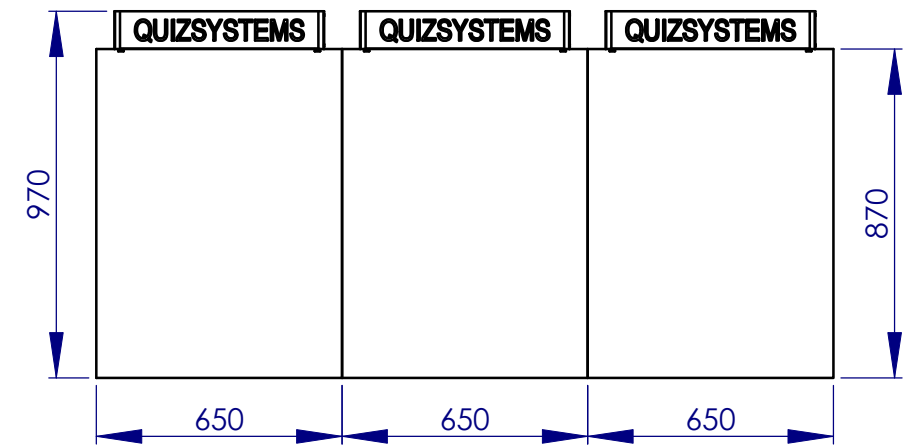

970

870

650

650

650

<b>QUIZSYSTEMS</b> MODULAR TABLE SURROUNDS	TIMBER FLATS - FELT (OR SUEDE) COVERED		 <p>195 Thornhill Road          Surbiton Surrey KT6 7TG          Tel: +44 (0)20 8288 0246          E: web@quizsystems.co.uk          W: www.quizsystems.co.uk</p>
	REVISION: 0	DO NOT SCALE FROM THIS DRAWING	
	DATE: 03/07/10 DRAWN: JOHN WALKER	IF IN DOUBT - ASK!	